

**Assembly and operating instructions**  
**Elastic coupling**

**Nor-Mex<sup>®</sup> MV**



---

## Content

Chapter	Page
1 Notes on safety.....	2
2 Function.....	3
2.1 Appropriate Use.....	3
3 Marking of the coupling.....	3
4 Storage.....	4
5 Construction.....	4
6 Technical data.....	5
7 Assembly.....	7
7.1 Pay attention before the assembly.....	7
7.2 Finished borehole.....	7
7.3 Installing coupling.....	8
8 Adjusting coupling.....	10
8.1 Angular misalignment $\square K_w$ .....	11
8.2 Radial displacement $\square K_r$ .....	11
8.3 Axial displacement.....	12
9 Operation.....	13
10 Maintenance.....	16
10.1 Wear Inspection on the Buffer Ring.....	16
10.2 Wear limit of elastic buffers.....	17
10.3 Changing the elastic intermediate ring.....	18
11 Waste Disposal.....	18

---

## 1 Notes on safety

The present assembly and operating instruction (AOI) constitutes a part of the coupling supply. Always keep the AOI near the coupling well accessible.

The German version of this manual is the predominant and binding version.

Make sure that all persons charged with the assembly, operating, service, and maintenance have read and understood the AOI and follow all the points:

- Avert hazards for body and life of the user and third parties.
- Ensure the operating safety of the coupling.
- Avoid the loss of use and environmental impairment through false handling.

In the case of transport, mounting, dismounting and maintenance, attention is to be paid to the relevant regulations for industrial safety and for environmental care.

The coupling may only be operated, mounted, serviced and maintained by authorised and trained personnel.

The user must take into account that the bolting elements of coupling parts may be adversely affected by the heat produced by a brake disk/ brake drum due to the resultant friction. Make sure that the combination of the employed brake lining with the material of the brake disk/ brake drum does not lead to sparks or impermissible thermal growth. The brake disk is

normally made of steel, and the brake disk is normally made of cast iron with nodular graphite. In case of any doubt, please consult the supplier!

In the interest of further development, we reserve the right to make changes which serve technological progress.

By the use of accessories and spare parts, which were not originally manufactured by TSCHAN GmbH, we are not responsible for any resulting damage or liability or guarantee.

---

## 2 Function

The coupling NOR-Mex<sup>®</sup> MV is a torsionally elastic and puncture-proof claw coupling. It balances out angular, radial and axial shaft misalignments within defined limits. The coupling transfers the torque via pressure loadable, elastic buffers of Perbunan (Pb) which are joined together as an intermediate ring.

The elastic intermediate ring can cushion impacts and torsional vibrations; it is oil-tight and electrically conductive.

The coupling is usable in every sense of rotation and installation position.

### 2.1 Appropriate Use

- In order to ensure a faultless, lasting operation of the coupling, it must be laid out according to the layout instructions e.g. DIN 740 part 2 (or also catalogue NOR-Mex<sup>®</sup>) with an operating factor corresponding to the operating conditions.
- The coupling must only be operated in normal industrial atmospheres. Since aggressive media may attack the coupling components, screws and elastic buffer rings, they represent a risk for the operational safety of the coupling. Consult TSCHAN GmbH in such cases.
- Apart from incorporating a finished bore hole with parallel key groove (see „7.2 Finished borehole“) no further changes can be carried out on the coupling.
- The coupling may only be used within the framework of the conditions defined in the performance and delivery contract.
- Every change of the conditions of use or the operating parameters necessitates a new verification of the coupling layout.

---

## 3 Marking of the coupling

The product line NOR-Mex<sup>®</sup> has its hardness in Shore (A) indicated on the elastic intermediate ring.

## 4 Storage

On receipt of the goods, the supply is to be checked immediately for completeness and correctness. Possible damages incurred during transit and / or missing parts are to be notified in writing.

The coupling parts can be stored in their delivered standard-state for 6 months in a dry, roofed place at normal room temperature. For a longer storage duration a long-term preservation is necessary (consult TSCHAN GmbH). The elastic intermediate ring must not be subjected to ozone containing mediums, direct solar influence or strong light sources with ultraviolet-light. The relative humidity must not exceed 65%. In the case of proper storage the characteristics of the elastic intermediate ring remain unchanged for almost up to three years.

## 5 Construction

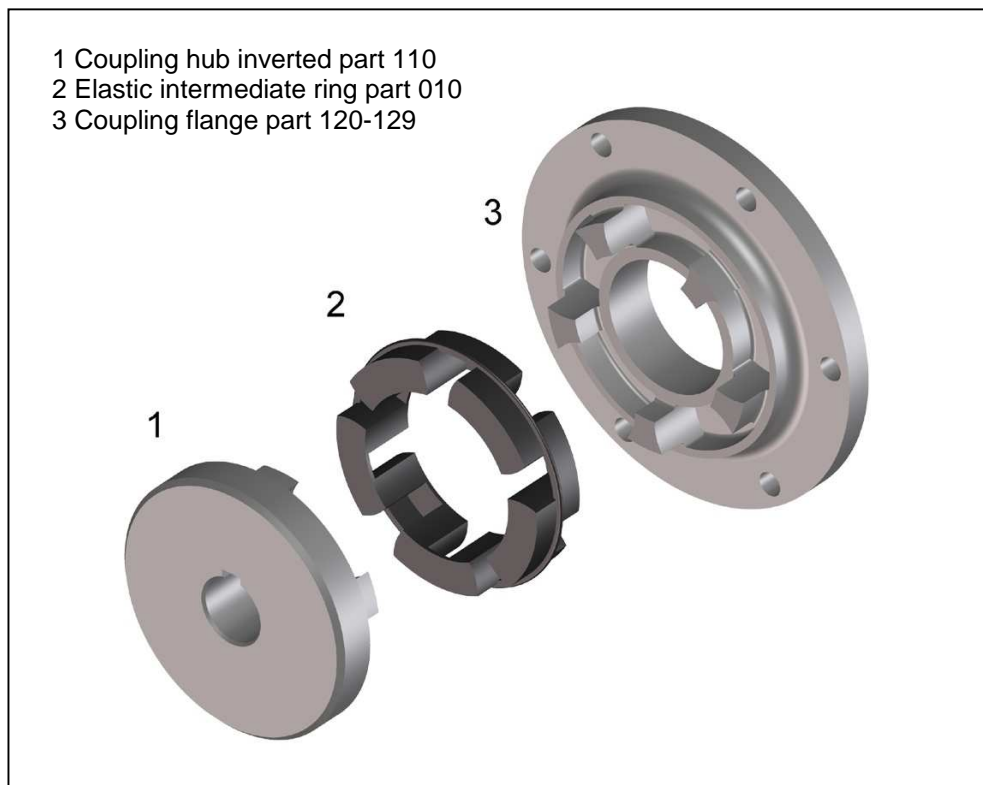

Fig. 1 Construction **Nor-Mex<sup>®</sup> MV**

## 6 Technical data

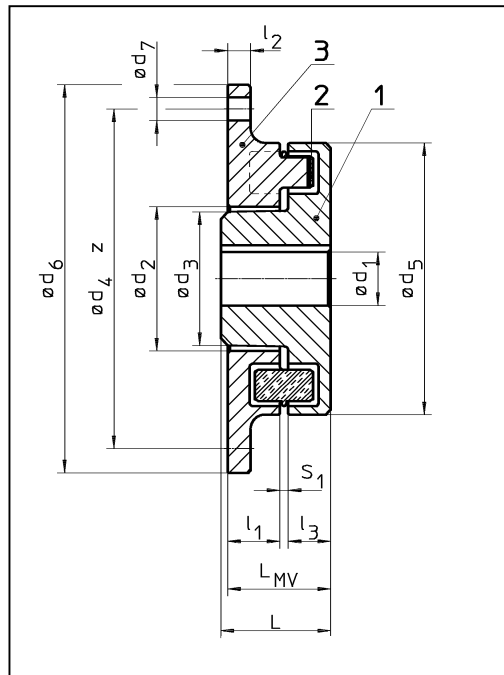

Fig. 2 Nor-Mex<sup>®</sup> MV

Table 1 Technical data:

Size Nor-Mex MV	T <sub>Cnom</sub> Pb72 [Nm]	T <sub>Cpeak</sub> Pb72 [Nm]	T <sub>Cnom</sub> Pb82 [Nm]	T <sub>Cpeak</sub> Pb82 [Nm]	n <sub>max</sub> [min <sup>-1</sup> ]
97	96	200	150	340	7000
112	150	310	230	540	6000
128	250	500	380	860	5000
148	390	800	600	1350	4500
168	630	1300	980	2250	4000
194	1050	2000	1650	3630	3500
214	1500	3100	2400	5400	3000
240	2400	4800	3700	8650	2750
265	3700	7500	5800	13500	2500
295	4900	10000	7550	18000	2250
330	6400	13000	9900	23400	2000
370	8900	18200	14000	32750	1750
415	13200	27000	20500	49000	1500

Size Nor-Mex MV	d <sub>1</sub> max [mm]	d <sub>2</sub> [mm]	d <sub>3</sub> [mm]	d <sub>4</sub> [mm]	d <sub>5</sub> [mm]	d <sub>6</sub> f7 [mm]	d <sub>7</sub> [mm]	z quan- tity	l <sub>1</sub> [mm]	l <sub>2</sub> [mm]	l <sub>3</sub> [mm]	L [mm]	L <sub>MV</sub> [mm]	S <sub>1</sub> [mm]	m undrilled [kg]	
97-6,5"	30	49,5	45	200,02	97	215,90	9,5	6	20	10	15,0	38	38	3,0	5,2	
112-6,5"	35	59,5	55	200,02	112	215,90	9,5	6	22	10	17,5	43	43	3,5	5,4	
112-7,5"				222,25		241,30		8							4,4	
128-7,5"	42	69,5	65	222,25	128	241,30	9,5	8	25	13	19,5	48	48	3,5	6,6	
128-8"				244,47		263,52		6							7,3	
128-10"				295,27		314,32		8							9,3	
148-8"				244,47		263,52		6							9,0	
148-10"	55	89,5	85	295,27	148	314,32	11,0	8	28	13	21,5	60	53	3,5	11,1	
168-10"				295,27		314,32		8							13,9	
168-11,5"	60	99,5	95	333,37	168	352,42	11,0	8	34	13	27,5	70	65	3,5	15,6	
194-11,5"				333,37		352,42		8							21,1	
194-14"	70	114,5	107	438,15	194	466,72	14,5	8	38	16	33,5	80	75	3,5	29,4	
214-11,5"				333,37		352,42		8							25,3	
214-14"	80	129,5	122	438,15	214	466,72	14,5	8	42	16	36,0	90	82	4,0	33,5	
240-11,5"				333,37		352,42		8							37,7	
240-14"	90	144,5	137	438,15	240	466,72	14,5	8	45	20	43,0	100	92	4,0	42,7	
240-16"				489,00		517,52		8							50,5	
265-11,5"	100	159,5	152	333,37	265	352,42	11,0	8	50	20	49,5	110	105	5,5	46,7	
265-14"				438,15		466,72									8	52,0
265-16"				489,00		517,52									14,5	57,7
265-18"				542,92		571,50									18,0	63,7
295-14"				438,15		466,72									8	58,7
295-16"	110	169,5	160	489,00	295	517,52	14,5	8	52	22	45,0	120	105	8,0	65,0	
295-18"				542,92		571,50									6	68,7
295-21"				641,40		673,10									18,0	72,3
330-18"				542,92		571,50									6	102,7
330-21"	120	199,5	190	641,40	330	673,10	18,0	12	56	25	66,0	160	130	8,0	115,7	
330-24"				692,20		733,40									22,0	124,9
370-18"	140	234,5	225	542,92	370	571,50	18,0	6	62	25	60,0	160	130	8,0	113,9	
370-21"				641,40		673,10									12	135,5
370-24"				692,20		733,40									22,0	151,5
415-18"				542,92		571,50									6	144,2
415-21"	160	269,5	260	641,40	415	673,10	18,0	12	65	30	67,0	170	140	8,0	170,4	
415-24"				692,20		733,40									22,0	186,6

The torque  $T_{Cnom}$  and  $T_{Cpeak}$  is valid for:

- Intermediate rings of Perbunan Pb72 and/or Pb82,
- Ambient temperatures of -40 °C to +60 °C,
- Operation within the stipulated alignment values.

During the layout of the coupling according to DIN 740 part 2 (or also catalogue Nor-Mex<sup>®</sup>) different factors must be considered:

- with higher temperatures a corresponding temperature factor  $S_v$
- according to the starting frequency a starting factor  $S_z$
- in dependence of the operating conditions an impact factor,  $S_A$ ,  $S_L$

With circumferential speeds of more than 22 m/s, we recommend to balance the coupling.

## 7 Assembly

### 7.1 Pay attention before the assembly



- **Danger of injuries!**
  - **Disconnect the drive before carrying out any work on the coupling!**
  - **Secure the drive against unintentional re-start and rotation!**
  - **Incorrectly tightened bolts can cause serious personal injuries and property damages!**
  - **In compliance with accident prevention regulations, you are obliged to protect all freely rotating parts by means of permanently installed guards/ covers against unintentional contact and falling down objects.**
  - **To avoid sparks, the covers for couplings used in explosive atmospheres should be made of stainless steel!**
  - **As a minimum, the covers have to fulfil the requirements of protection type IP2X.**
  - **The covers have to be designed to prevent dust from depositing on the coupling.**
  - **The cover must not contact the coupling or impair the proper function of the coupling.**
- 
- Make sure that the speeds, torques and ambient temperatures as stated in chapter 6 'Technical Data' are not exceeded.
  - The maximum permissible bore diameters must not be exceeded.
  - Check whether the shaft-hub connections safely transmit the occurring operating torques.
  - The standard tolerance of TSCHAN for finish bores is fit H7.
  - Standard keyways comply with DIN 6885, sheet 1.
  - Check the dimensions and tolerances of shafts, hub bores, keys and keyways.
  - Set screws as required.

### 7.2 Finished borehole

For the completion of the finished borehole in a coupling hub, pay attention to following procedure:

- Clean the coupling hub of preservatives.
- Tighten the coupling hub to the faces marked with  $\Gamma$  and carefully align the coupling hub.
- The indicated values in table 1 for  $\varnothing d_{1max}$  are valid for a parallel key connection according to DIN 6885/1 and must not be exceeded.
- Choose the borehole fit so that during the union with the shaft tolerance a wringing fit and/or an interference fit as for example at H7/m6 is carried out.
- Provide a setscrew for axial securing on the hub back above the parallel key slot.

In the case of other shaft hub connections consultation with TSCHAN GmbH is necessary.



- The maximum indicated borehole diameters are valid for a:
- Parallel key connection according to DIN 6885/1 and must not be exceeded.
- In the case of transgression of these values the coupling can sever.
- Through flying away fragments danger exists!

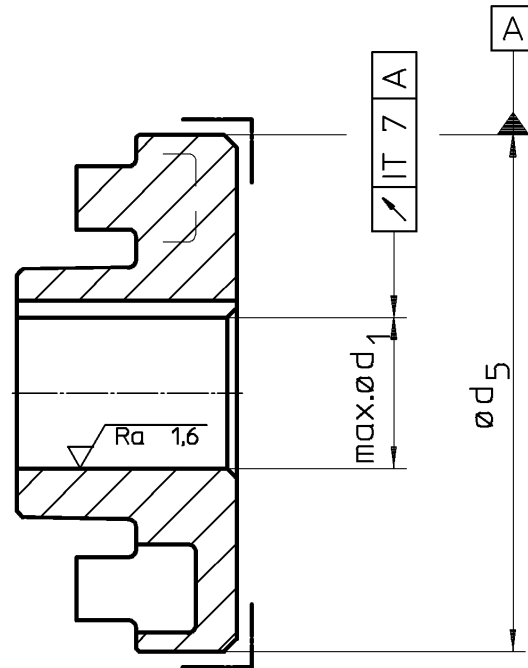

### 7.3 Installing coupling

- Remove the elastic intermediate ring (Figure 3, Pos. 1).
- Clean the borehole of the flange hub and the shaft end before installing. The surfaces must be clean, dry and grease-free.
- Use suitable installation aids and hoists such as cranes or pulley blocks in the case of bigger couplings.
- Pull the flange hub onto the shaft end in its intended position (Figure 3, Pos.2).

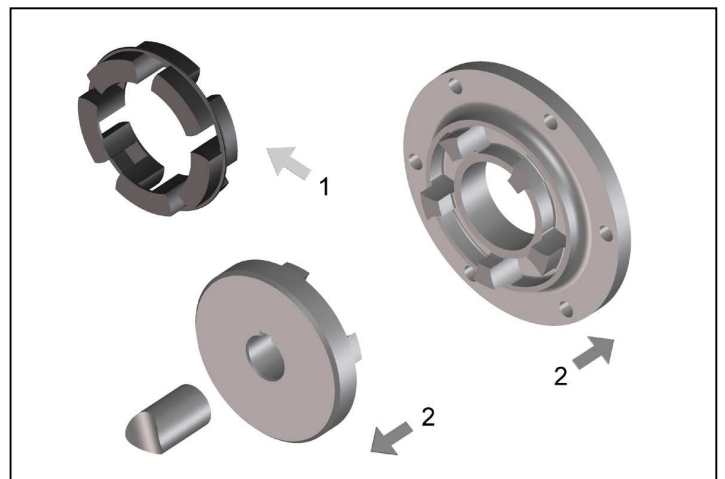

Fig. 3

#### Reference:

For easier installation a uniform warming of the hub between 80 °C to 120 °C is safe.





- **Warning!**
- **Only work with gloves as a protection against hot parts of the coupling!**

- Mount the hub so that the shaft end is even with the interior borehole opening (Figure 4). Pay attention to possible differing agreements!
- Secure, possible available setscrews against automatic loosening and flying out by tightening with an adhesive e.g. Loctite 222.
- Mount the coupling flange onto the flange connection. Pay attention that the parts do not tilt during the joining onto the centring seat (Figure 3, Pos.2).

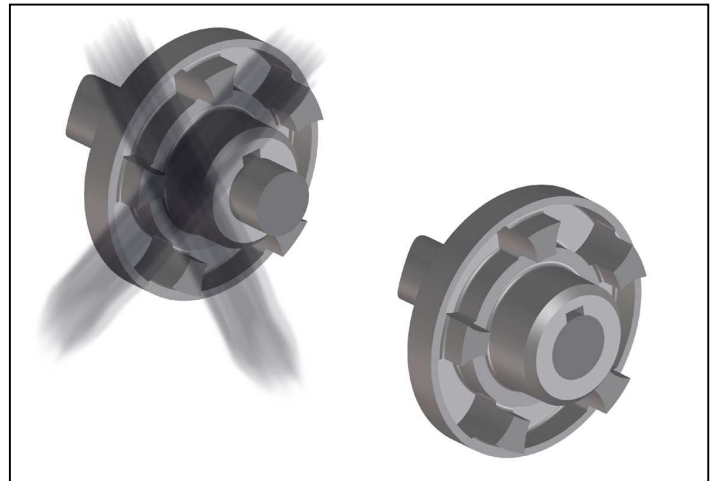

Fig. 4

**ATTENTION!**

The bearing surfaces of the coupling flange and flange connection must be clean, dry and grease-free. Balanced parts are position marked to each other.

Let the hot hubs cool off to ambient temperature before the introduction of the intermediate ring.

- For easier mounting, the elastic intermediate ring can be provided with a slip additive (e.g. Talcum) before introduction.
- Fit the intermediate ring into one half of the coupling.
- Push the shaft end with the mounted coupling half and the coupling flange together (Figure 5).
- Adjust the coupling according to the following specifications in "8 Coupling adjustment".

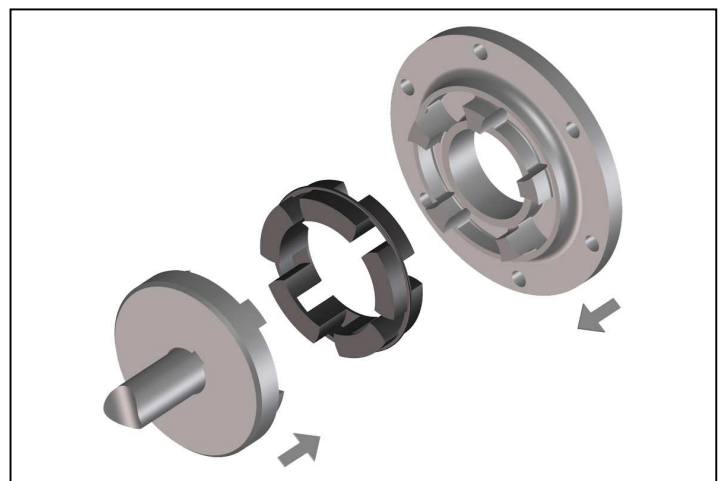

Fig. 5

## 8 Adjusting coupling



- **Injury hazard!**
- **Switch-off the drive before all work on the coupling!**
- **Secure the drive against unintentional switching on and rotating!**
- **Reference:**
- **An exact alignment of the coupling increases the service life of the elastic intermediate ring and lessens hazards by.**
- **Do not exceed the maximum permissible displacement values. The overstepping of these values results in coupling damage and breakdown!**

- When aligning the cold equipment take into account the expected thermal growth of the components, so that the permissible misalignment values for the coupling are not exceeded in operation.
- Be aware that the coupling under misalignment imposes restoring forces on the adjacent shafts and bearings. Take into account that the larger the misalignment, the greater the restoring forces will be.
- The displacements values indicated in the tables 2 to 4 are maximum permissible guide numbers.  
We recommend not to fully utilise these values during the alignment, so that in operation sufficient reserves remain for thermal expansions, foundation settlements etc.
- In special cases with high demands on quiet running or high rotating speeds it is possible that, in the three displacement levels, an alignment accuracy of  $\leq 0,1$  mm is necessary.
- If the coupling is mounted in a closed housing / casing so that a subsequent alignment is not possible any more, it must be guaranteed that the geometry and fit accuracy of the contact surfaces in operation aligns the shafts exactly within the mentioned tolerances.

### 8.1 Angular misalignment $\Delta K_w$

- Measure on the face of the external diameter a complete rotation (360°). Determine in this case the greatest deviation  $\Delta K_{w1}$  as well as the smallest deviation  $\Delta K_{w2}$  (Figure 6).
- Calculate the angular misalignment  $\Delta K_w = \Delta K_{w1} - \Delta K_{w2}$ .
- The values in table 2 are valid for a reference rotation speed of  $1500 \text{ min}^{-1}$ .

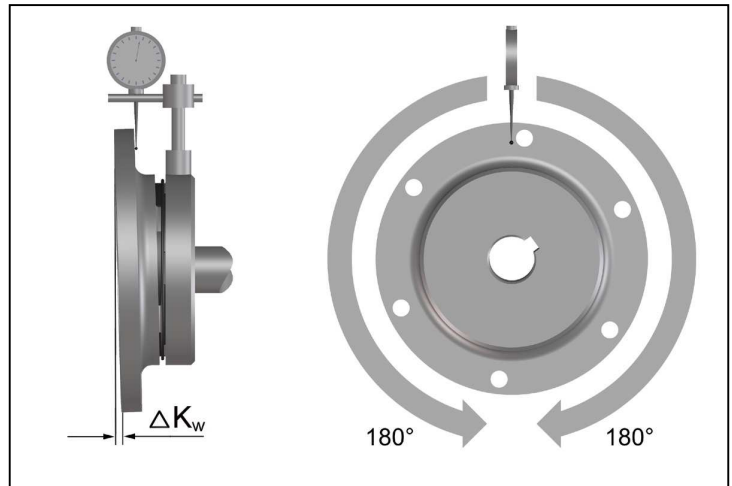

Fig. 6

**Table 2 Maximum permissible displacement values - angular:**

Size	97	112	128	148	168	194	214	240	265	295	330	370	415
$\Delta K_{w \text{ max}}$ [mm]	0,2	0,3	0,3	0,3	0,3	0,3	0,3	0,3	0,3	0,3	0,3	0,3	0,3

### 8.2 Radial displacement $\Delta K_r$

- Measure a complete rotation (360°). Determine in this case the greatest deviation  $\Delta K_{r1}$  as well as the smallest deviation  $\Delta K_{r2}$  (Figure 7).
- Calculate the radial displacement  $\Delta K_r = 0,5 \times (\Delta K_{r1} - \Delta K_{r2})$ . Pay attention to the operational sign of the measured values.
- The values of table 3 are valid for a reference rotation speed of  $1500 \text{ min}^{-1}$ .

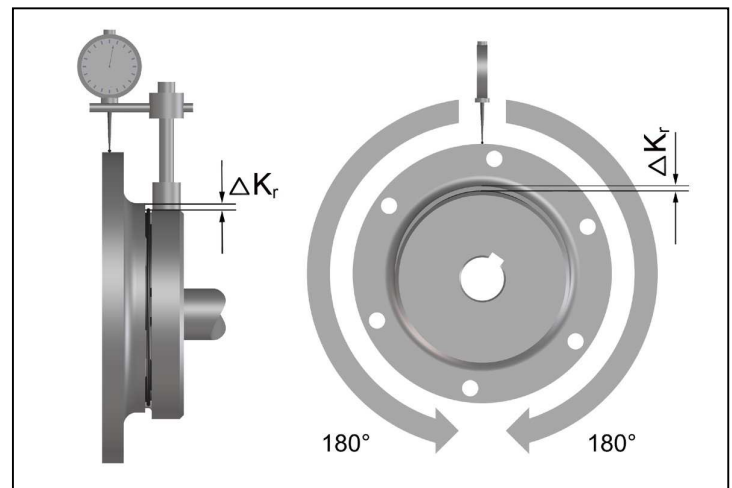

Fig. 7

**Table 3 Maximum permissible displacement values - radial:**

Size	97	112	128	148	168	194	214	240	265	295	330	370	415
$\Delta K_{r \text{ max}}$ [mm]	0,2	0,3	0,3	0,3	0,3	0,3	0,3	0,3	0,3	0,3	0,3	0,3	0,3

### 8.3 Axial displacement

- Measure the axial S gap measurement according to figure 8.
- Keep, when aligning the gap measurement S, to the maximum permissible tolerance X according to table 4.

**ATTENTION!**

If greater axial displacements are expected in operation, consultation with TSCHAN GmbH is necessary.

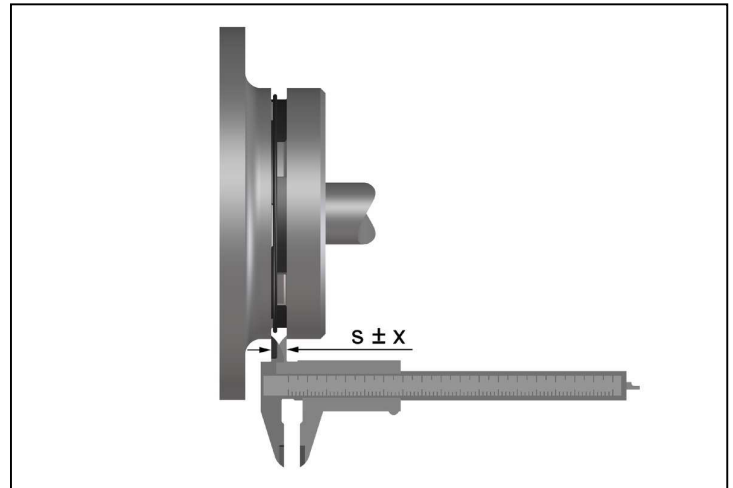

Fig. 8

**Table 4 Recommended alignment values - axial:**

Size	97	112	128	148	168	194	214	240	265	295	330	370	415
S [mm]	3	3,5	3,5	3,5	3,5	3,5	4	4	5,5	8	8	8	8
X [mm]	±1	±1	±1	±1	±1,5	±1,5	±2	±2	±2,5	±2,5	±2,5	±2,5	±2,5

## 9 Operation

With the application of the coupling, attention is to be paid to its characteristics (see “6 Technical data”). These cannot in any case be exceeded without written permission from TSCHAN GmbH.

In order to ensure a faultless, lasting operation of the coupling, it must be laid out according to the instructions e.g. DIN 740 part 2 (or also catalogue NOR-MEX<sup>®</sup>) with an operating factor corresponding to its operating conditions.

Every change of the conditions of use or the operating parameters makes an inspection of the coupling layout urgently necessary.



- **Injury hazard!**
- **Switch-off the drive before all work on the coupling!**
- **Secure the drive against unintentional switching on and rotating!**
- **Through incorrectly tightened screws parts can fly away and cause serious injuries to persons and material damage!**
- **Check before commissioning the coupling its alignment and all screw fixings for their specified tightening torque and/or firm seating!**
- **Before commissioning the plant all protective devices against unintentional touching of free moving and/or rotating parts must be installed.**
- **To avoid sparks coverings in stainless steel should be used!**
- **The coverings must fulfil at least the demands of protection type IP2X.**
- **The covering is to be so designed that it does not deposit dust onto the coupling parts.**
- **The covering must not touch the coupling or influence it in its functioning.**

**Pay attention during the operation of the coupling to:**

- Changed running noises
- Occurring vibrations

**Attention!**

- **If irregularities are found during the operation of the coupling, immediately disconnect the drive.**
- Detect according to the following table 5 “Operating faults and their possible causes” the fault cause and remove it.  
The listed faults are some examples which are supposed to facilitate fault location.
- **For fault finding and elimination all machine components and operating states are to be considered!**

**Table 5 Operating faults and their possible causes:**

<b>Trouble</b>	<b>Cause</b>	<b>Risk Warning</b>	<b>Correction</b>
Irregular running noises/vibrations	Alignment fault	Considerable increase in coupling temperature. Premature wear of elastic buffers. Increased reaction forces act on connected machines.	<ul style="list-style-type: none"> <li>- Disconnect drive</li> <li>- Remove cause for alignment fault</li> <li>- Re-align coupling</li> <li>- Inspect elastomer for wear</li> </ul>
	Elastomer worn out	Coupling claws strike against each other. Spark formation, claw fracture, increased reaction forces.	<ul style="list-style-type: none"> <li>- Disconnect drive</li> <li>- Check coupling components for damages and replace parts, if necessary</li> <li>- Replace elastomer</li> </ul>
	Unbalance	Considerable increase in coupling temperature. Premature wear of elastic buffers. Increased reaction forces act on connected machines	<ul style="list-style-type: none"> <li>- Disconnect drive</li> <li>- Verify balance state of plant components and correct it, if necessary</li> <li>- Inspect elastomer for wear</li> </ul>
	Loose screw connections	Flying off parts can cause serious injuries and considerable damages.	<ul style="list-style-type: none"> <li>- Disconnect drive</li> <li>- Check coupling parts for damages, replace parts, if necessary</li> <li>- Verify alignment of coupling</li> <li>- Tighten screws to the specified tightening torque and secure them against working loose, if necessary,</li> <li>- Inspect elastomer for wear</li> </ul>
Premature wear of elastomer	Alignment fault	Considerable increase in coupling temperature. Increased reaction forces act on connected machines.	<ul style="list-style-type: none"> <li>- Disconnect drive</li> <li>- Remove cause for alignment fault</li> <li>- Re-align coupling</li> <li>- Inspect elastomer for wear</li> </ul>
	Unacceptable temperatures	Material properties of elastic buffers change. The torque transmission capability is adversely affected.	<ul style="list-style-type: none"> <li>- Disconnect drive</li> <li>- Replace elastomer</li> <li>- Re-align coupling</li> <li>- Adjust ambient temperature</li> </ul>

Trouble	Cause	Risk Warning	Correction
	Contact with aggressive products	Material properties of elastic buffers change. The torque transmission capability is adversely affected.	<ul style="list-style-type: none"> <li>- Disconnect drive</li> <li>- Check coupling parts for damages and replace parts, if necessary</li> <li>- Replace elastomer</li> <li>- Verify alignment of coupling</li> <li>- Prevent contact with aggressive products</li> </ul>
	Torsional vibrations in the drive line	Considerable increase in coupling temperature. Premature wear of elastic buffers. Increased reaction forces act on connected machines.	<ul style="list-style-type: none"> <li>- Disconnect drive</li> <li>- Analyse and eliminate cause for torsional vibrations</li> <li>- Check coupling parts for damages and replace parts, if necessary</li> <li>- Replace elastomer and consult TSCHAN GmbH concerning eventual use of another Shore-hardness</li> <li>- Verify coupling alignment</li> </ul>
Claw breakage	Wear limit of elastomer exceeded ====> contact of claws	Coupling is destroyed. Connected machines can be affected, too.	<ul style="list-style-type: none"> <li>- Disconnect drive</li> <li>- Replace coupling</li> <li>- Inspect the elastomer for wear at shorter intervals</li> </ul>
	Overload due to too high torque	Coupling is destroyed. Connected machines can be affected, too.	<ul style="list-style-type: none"> <li>- Disconnect drive</li> <li>- Verify coupling design in cooperation with TSCHAN GmbH</li> <li>- Replace coupling</li> <li>- Install larger coupling, if necessary</li> </ul>

## 10 Maintenance

The elastic coupling NOR-Mex<sup>®</sup> -MV has in operation a low-maintenance.

Reaching the wear limit of the elastic intermediate ring depends on the operating parameters and the conditions of use.

In the case of routine monitoring work on the plant check:

- Alignment of the coupling
- Elastomer-state
- Remove dust deposits from the coupling parts and the intermediate ring.

### 10.1 Wear Inspection on the Buffer Ring



- **Danger of injuries!**
- **Disconnect the drive before carrying out any work on the coupling!**
- **Secure the drive against unintentional switching on and rotating!**

Perform a visual inspection and a wear inspection of the buffer ring after 2000 hours, or after 3 months at latest, after the first start-up of the equipment. If only minor wear or no wear is observed, further inspections of the plant can be carried out at regular intervals of 4000 hours, however, at least once a year, if the operating modes and conditions of the plant remain unchanged. However, should you observe excessive wear on the occasion of this first inspection already, check whether the cause for the problem is listed in table 5 "Operation faults and possible causes". In such a case, the inspection intervals must be adapted to the prevailing service conditions.

On the occasion of routine inspections or maintenance work on the drive equipment, or after 3 years at latest:

- Replace the elastic buffer ring.
- If the wear limit has been reached or exceeded, replace the buffer ring immediately, irrespective of the inspection intervals of the equipment.
- Check the alignment of the coupling.
- Remove dust deposits from the coupling components and buffer ring.



## 10.2 Wear limit of elastic buffers

Replace the elastic buffer ring as soon as the coupling has a distinct torsional backlash, or if the minimum buffer thickness ( $PD_{min}$ , Fig. 9) acc. to table 6 has been reached.

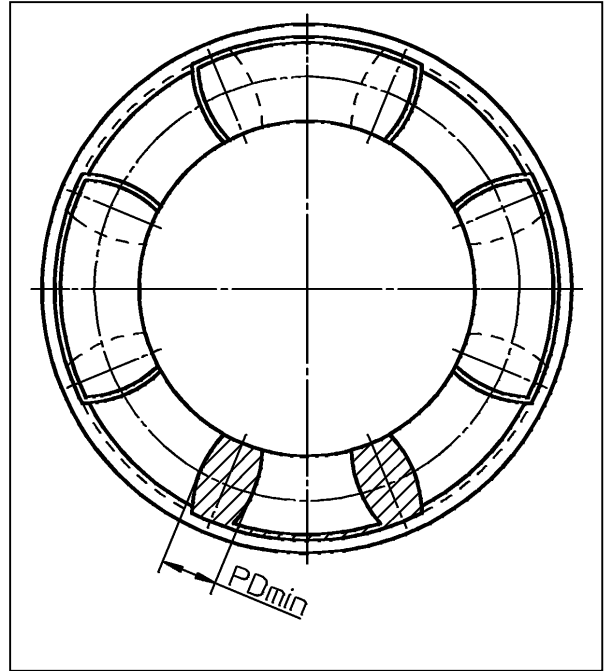

Fig. 9 Buffer thickness

Table 6 Minimum buffer thickness  $PD_{min}$ :

Size	97	112	128	148	168	194	214	240	265	295	330	370	415
$PD_{min}$ [mm]	9	9	9	10	10	10	10	11	12	13	14	16	17

### 10.3 Changing the elastic intermediate ring



- **Injury hazard!**
- **Switch-off the drive before all work on the coupling!**
- **Secure the drive against unintentional switching on and rotating!**

- Pull back the shaft with mounted coupling hub (Figure 10, Pos.1).
- Remove the intermediate ring (Figure 10, Pos.2).
- For easier mounting, the new intermediate ring can be provided with a slip additive before introduction (e.g. Talcum).
- Insert a new intermediate ring.
- Push the coupling halves together again.
- Adjust the coupling according to the following specifications in "8 Coupling adjustment".

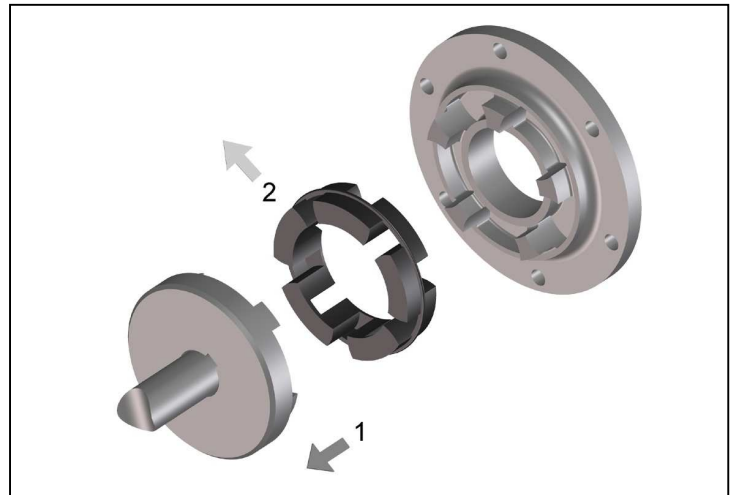

Fig. 10

#### Warning!



- **Before commissioning the plant, install all protective devices against unintentional touching of free rotating parts.**
- **To avoid sparks coverings in stainless steel should be used in explosion hazardous areas.**
- **The coverings must fulfil at least the demands of protection type IP2X.**
- **The covering is to be so designed that it does not deposit dust onto the coupling parts.**
- **The covering must not touch the coupling or influence it in its function.**

When using accessories and spare parts which were not originally manufactured by TSCHAN GmbH, no liability or guarantee for any damages will be accepted.

## 11 Waste Disposal

The waste disposal has to occur according to the specific regulations of the respective user country.